

DETAIL OF MOUNTING BLOCK

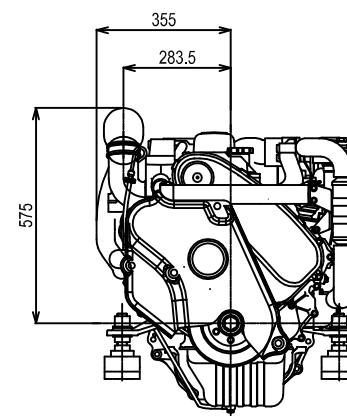

DETAIL OF COUPLING

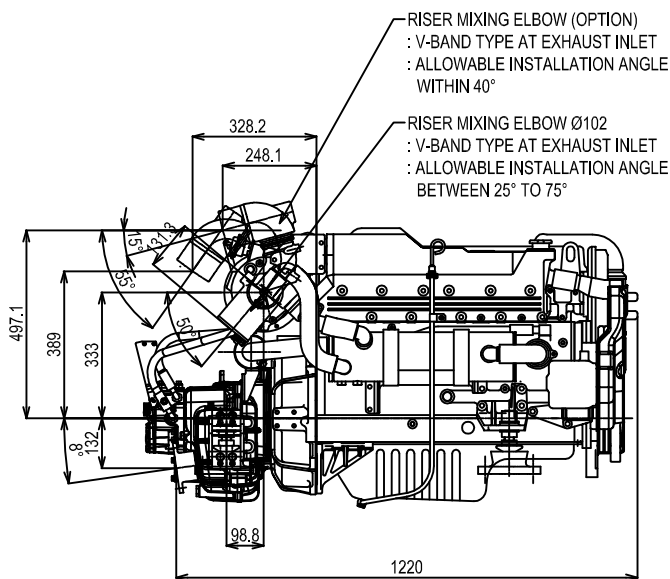
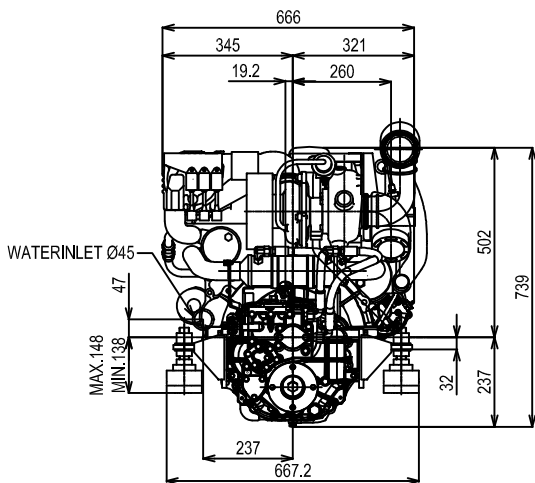
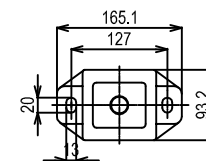
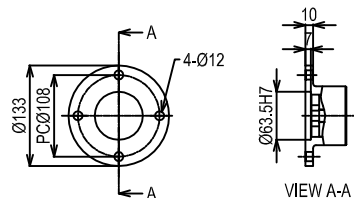

DIRECTION OF ROTATION

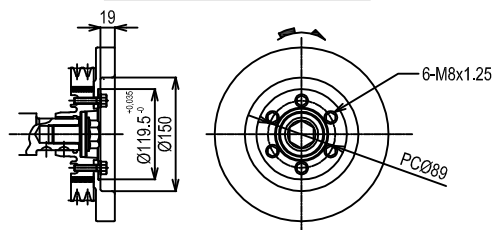

DETAIL OF PULLEY VIEWED FROM A

NOTE:

1. DWG. SHOWS MOUNTING BLOCKS AT ORIGINAL HEIGHT. ENGINE WEIGHT WILL COMPRESS BLOCKS BY 4MM (APPROX).
2. MOUNTING BLOCKS ARE EQUIPPED FOR STANDARD ACCESSORY.
3. ● SHOWS THE CENTER OF GRAVITY.
4. FOR ADDITIONAL INSTALLATION INFORMATION AND SPECIFICATIONS PLEASE REFER TO THE YANMAR ENGINE INSTALLATION MANUAL

Series: LP	Engine: 6LPA-STP2xKM50A	Reference: R2008-01
Scale: 1:10	Date: 01-10-08	Dimension: mm

