

MARINE DIESEL ENGINES

**6HA2M-HTE
6HA2M-DTE
283~327.3kW(385~445hp)**

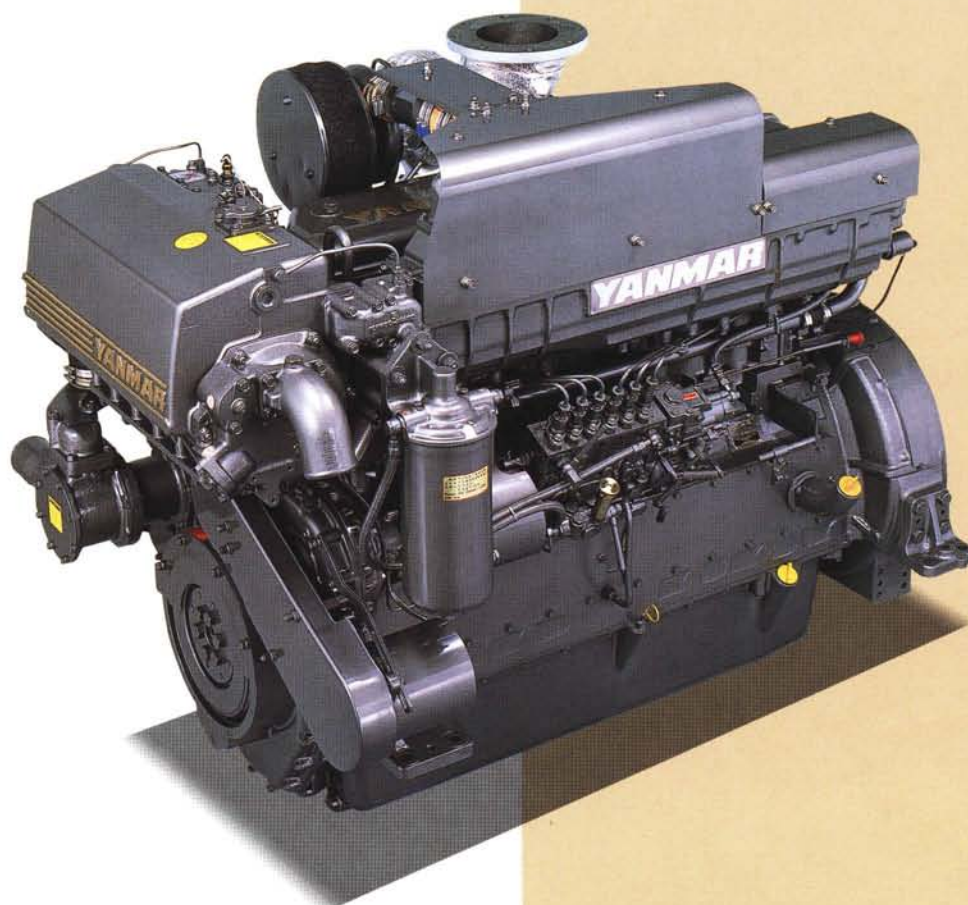

YANMAR®



Photograph may show optional equipment.

Fuel-Saving Formulas for Fishermen

PERFORMANCE CURVES

6HA2M-HTE

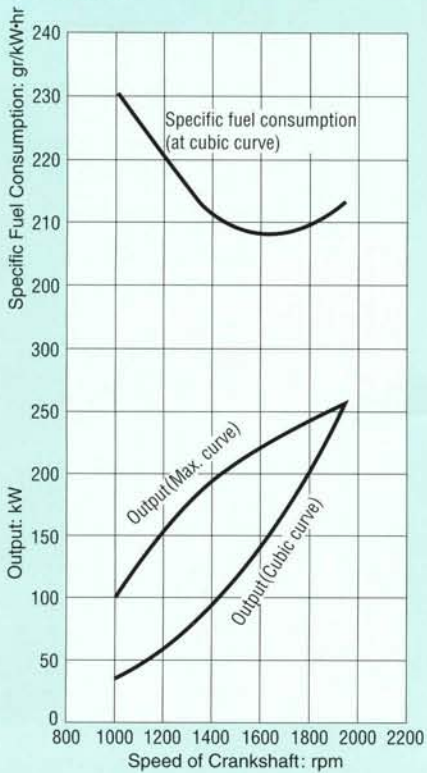

6HA2M-DTE

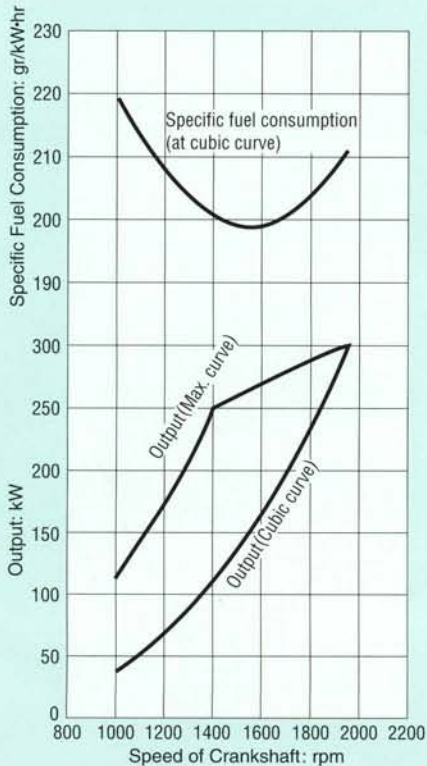

DIMENSIONS

Unit:mm

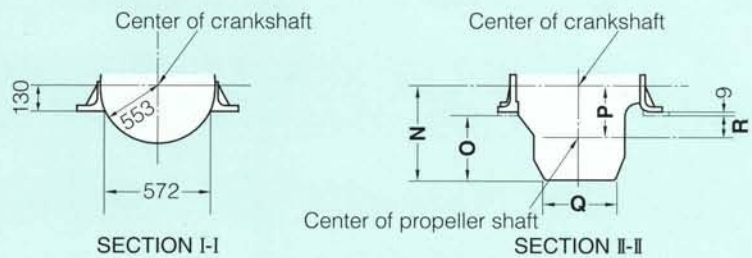
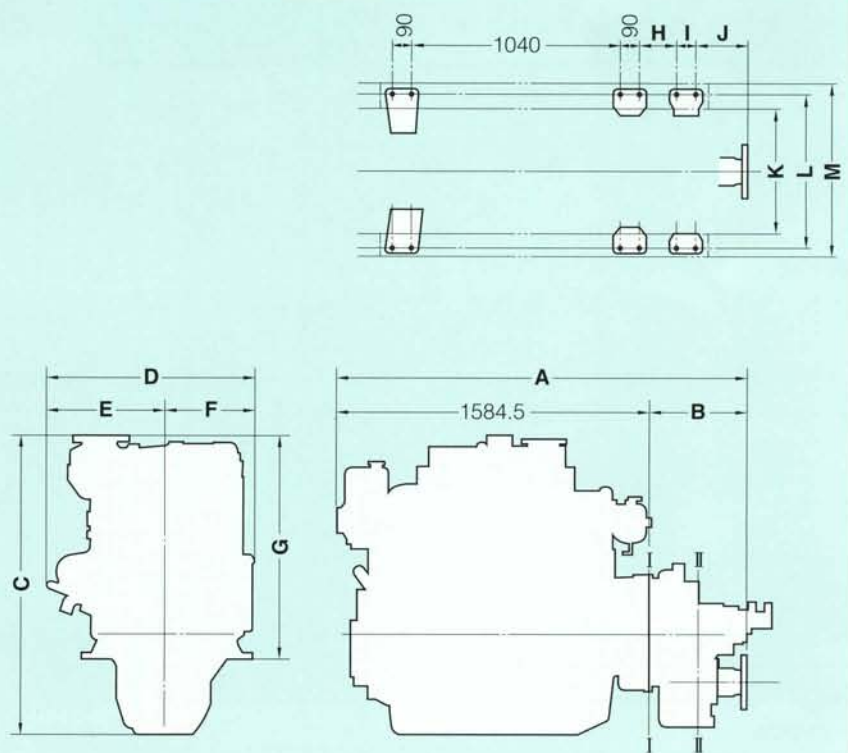

Model	A	B	C	D	E	F	G	H	I
6HA2M-HTE	1584.5	—	1260	1016	499	517	874	—	—
6HA2M-HTE x YX-120	2004.5	420	1272	1016	499	517	874	134.5	120
6HA2M-HTE x YX-120L	2038.5	454	1384	1016	499	517	874	145.5	120
6HA2M-DTE	1584.5	—	1260	1036	519	517	874	—	—
6HA2M-DTE x YX-120	2004.5	420	1272	1036	519	517	874	134.5	120
6HA2M-DTE x YX-120L	2038.5	454	1384	1036	519	517	874	145.5	120

Model	J	K	L	M	N	O	P	Q	R
6HA2M-HTE	—	570	700	750	386	247	—	—	—
6HA2M-HTE x YX-120	187	581	700	781	398	259	208	317	69
6HA2M-HTE x YX-120L	210	572	700	756	510	371	258	350	119
6HA2M-DTE	—	570	700	750	386	247	—	—	—
6HA2M-DTE x YX-120	187	581	700	781	398	259	208	317	69
6HA2M-DTE x YX-120L	210	572	700	756	510	371	258	350	119

Yanmar's 6HA2M Engine Provides Fuel

Getting the most boat performance out of the least amount of fuel is one of the top priorities of today's fishing boat owners. Which is why Yanmar has introduced this new marine diesel engine, specifically built for fuel-saving, ocean-going service. It is a no-nonsense engine built up of quality components developed from Yanmar's vast experience with marine engines, and the needs of the men who run them.

THRIFTY, NOT THIRSTY!

Direct injection = direct savings... Direct fuel injection helps you win the battle against rising fuel costs. This fuel injection system is partly responsible for the great fuel-saving features of the 6HA2M, and accounts for far less consumption than any precombustion types. **and direct starting.** Easy starting is another bonus point

scored by the direct injection system. **Effective cooling = efficient combustion.**

Maintenance of a constant high temperature by the fresh water cooling system is one of the secrets to the peak combustion characteristics of the engine. It also chops down on lube oil costs and keeps them low, even with long usage.

ALL-SPEED STABILITY!
Constant temp. cooling = constant performance.

The fresh water high temperature cooling also means you get non-fluctuating performance levels at all speeds, especially in low-load conditions. After starting, the ideal temperature for combustion is attained quickly and maintained by thermostatic control.

RELIABLE AND DURABLE!
Clean cooling = clear advantages. Another tremendous advantage of

this fresh water cooling system is that it reduces thermal wear and stress on cylinder liners and piston rings, prevents corrosion, reduces calcium deposits and makes valuable contributions to the reliability of the engine. Added to this efficient system is an internal oil jet cooling system acting on inner piston walls that reduces heat load at the circumference of the combustion chamber. One more way Yanmar increases durability.

Low vibration = less wear.

The minimal vibration of the engine has been achieved through the use of light-weight moving parts and precise balancing, making the machines more durable and less wear prone. Critical components such as stress bearing moving parts, valve trains and combustion chambers are made of special high grade metals that have proven to be most durable for high speed engines.

ENGINE SPECIFICATIONS

Model	6HA2M-HTE		6HA2M-DTE	
Type	4-cycle, vertical, turbo-charged diesel engine			
No. of cylinders	6 in-line			
Bore x stroke	mm(in.)		130 x 165(5.12 x 6.50)	
Displacement	lit.(cu.in.)		13.140(802)	
Output kW(hp)/rpm	Rated	257(350)/1950		298(405)/1950
	Max.	283(385)/2000		327.3(445)/2000
Fuel consumption	gr/kW-hr		214 (at rated output)	
Direction of rotation	Counter-clockwise viewed from stern (crankshaft)			
Combustion system	Direct injection			
Cooling system	Fresh water cooling with sea water & fresh water pumps			
Lubricating system	Forced lubrication with gear pump			
Starting system	Electric starting motor (DC 24V)			
Dry weight	kg(lbs)		1340(2954)	
			1350(2976)	

MARINE GEAR SPECIFICATIONS

Engine model	6HA2M-HTE						6HA2M-DTE								
Marine gear model	YX-120			YX-120L			YX-120			YX-120L					
Type	Hydraulic multi-disc clutch														
Reduction ratio	2.03	2.57	3.04	3.55	4.00	4.59	2.03	2.57	3.04	3.46	4.00	4.59			
Prop. shaft speed at rated output	rpm	961	759	641	549	488	425	961	759	641	564	488	425		
Direction of rotation	Clockwise at ahead position as standard, viewed from stern														
Dry weight	kg(lbs)			310(683)			385(848)			310(683)			385(848)		

ACCESSORIES

Remarks: ● Standard △ Optional

Item	Name of accessories	Q'ty	6HA2M-HTE 6HA2M-DTE
Installation	Installation plate for wooden boat	2	△
	Adjusting shim for engine	1set	△
	Adjusting shim for marine gear (YX120)	1set	△
	Installation bolt kit	1set	△
	Jack bolt	1set	△
	Chock liner, bolt & nut for steel bolt	1set	△
Air	Exhaust gas pipe	1	△
	Breather hose with fittings	1set	●
	Exhaust flexible joint (T/C out)	1	●
	Intake air filter	1	●
	Exhaust gas silencer	1	△
	Engine room ventilator	1set	△
Fuel oil	Drain separator	1	●
	Duplex type fuel filter (mounted on engine)	1	△
	Fuel sedimentary filter	1	△
	Fuel oil pipe	1	△
Lubrication oil	Evacuation hand pump	1	●
	Duplex type oil filter (mounted on engine)	1	△
Cooling system	Kingston cock	1	△
	Kingston valve	1	△
	Raw water filter (simplex)	1	△
	Bilge pump (electric type)	1	△
	Fresh water sub-tank	1	●

Item	Name of accessories	Q'ty	6HA2M-HTE 6HA2M-DTE
Cooling system	Raw water pipe	1	△
Electric device	Battery switch	1	△
	Charging alternator	1	●
	Starting motor (1-pole type)	1set	●
	Starting motor w/harness (2-pole type)	1set	△
	Battery	1set	△
	Remote control	Control head (2-handle type)	1
Control head (1-handle type)		1	△
Push-pull cable (~10m)		2	△
Push-pull cable (12m~20m)		2	△
Wireharness (4m × Q'ty)			△
Instrument panel for wheel house (D-type)		1	●
Dual type instrument panel (C-type)		1	△
Connection wireharness for dual panel		1	△
Engine panel (mounted on engine)		1	△
Emergency stop push button with solenoid		1	△
Over speed relay		1	△
Others		Half coupling (rough bore type)	1
	Standard spare parts	1	●
	Standard tool kit	1	●
	Operation manual	1	●
	Parts book for engine	1	△
	Service manual	1	△

INSTRUMENT PANEL CONTAINS FOLLOWING ITEMS

Unit: mm(in.)

Detail of instrument panel C-type

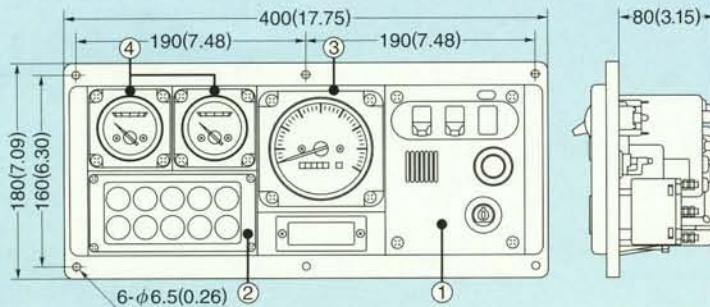

- ① **Switch unit**
 - Key switch
 - Alarm buzzer
 - Alarm buzzer stop switch
 - Illumination switch
- ② **Alarm lamp unit with Alarm monitor device**
 - Battery not charging
 - C.W. high temp.
 - L.O. low pressure
 - Clutch oil pressure
 - L.O. filter clogged
 - C.W. level
- ③ **Tachometer unit**
 - Tachometer with hour meter
- ④ **Sub meter unit**
 - L.O. pressure meter
 - C.W. temp. meter

Detail of instrument panel D-type

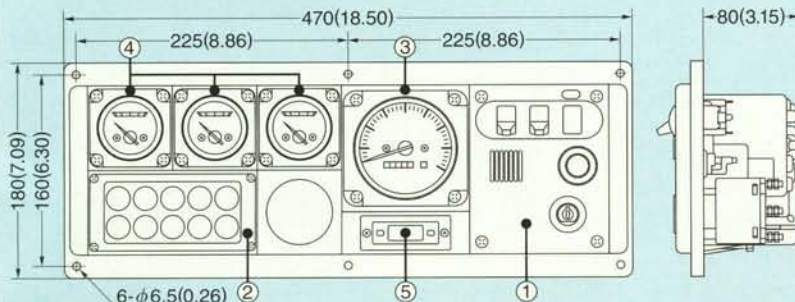

- ① **Switch unit**
 - Key switch
 - Alarm buzzer
 - Alarm buzzer stop switch
 - Illumination switch
- ② **Alarm lamp unit with Alarm monitor device**
 - Battery not charging
 - C.W. high temp.
 - L.O. low pressure
 - Clutch oil pressure
 - L.O. filter clogged
 - C.W. level
- ③ **Tachometer unit**
 - Tachometer with hour meter
- ④ **Sub meter unit**
 - L.O. pressure meter
 - C.W. temp. meter
 - Boost meter (Turbo)
- ⑤ **Clock unit**
 - Clock



YANMAR CO., LTD.

1-32, Chayamachi, kita-ku, Osaka 530-8611, JAPAN
<http://www.yanmar.co.jp>

Note: All data subject to alteration without notice.