

DETAIL OF MOUNTING BLOCK

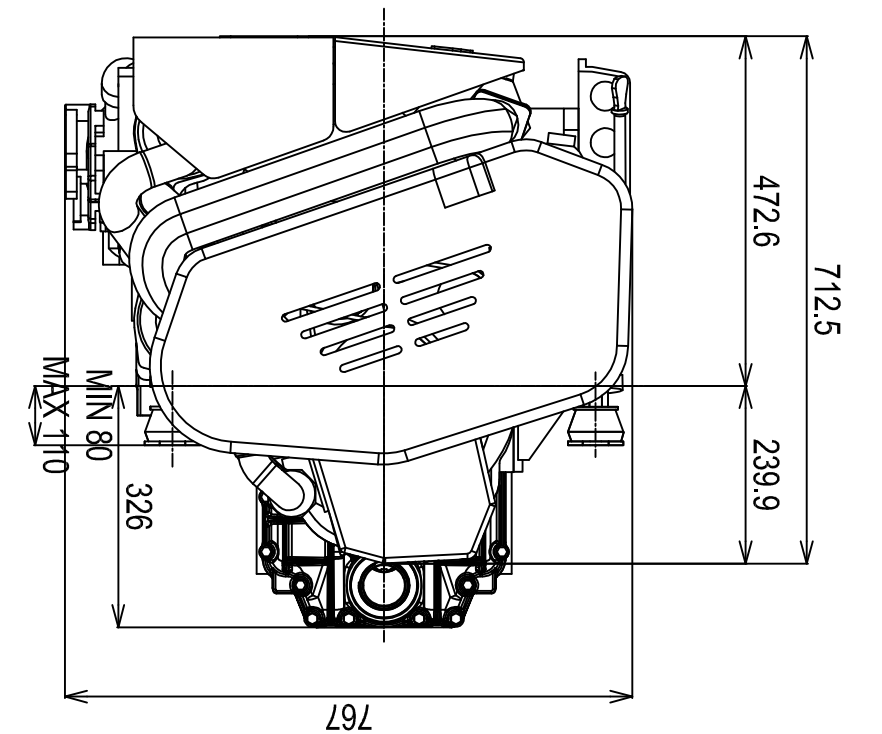

DETAIL OF COUPLING

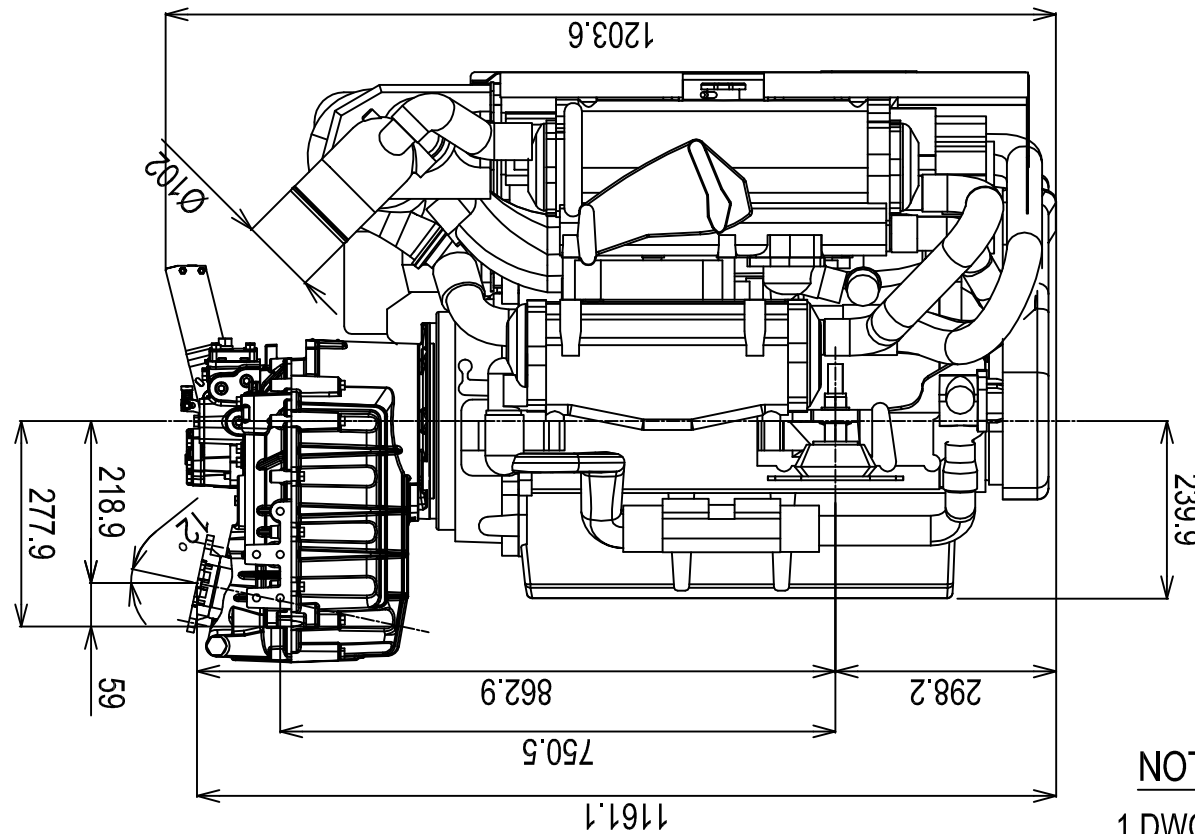
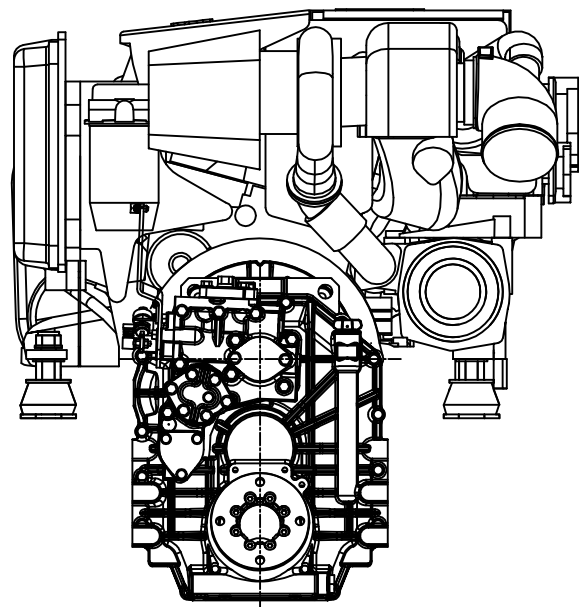
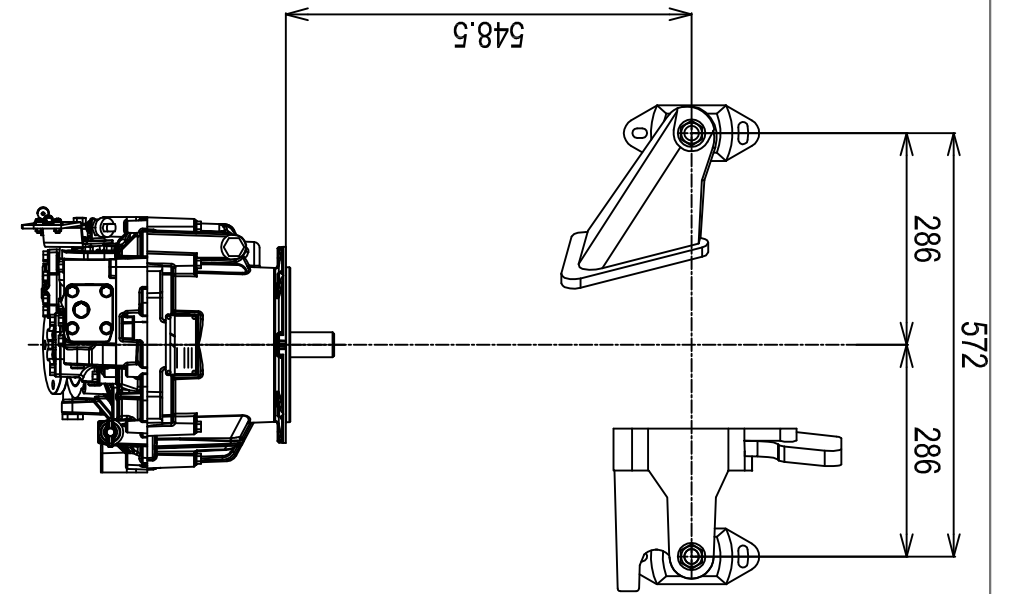
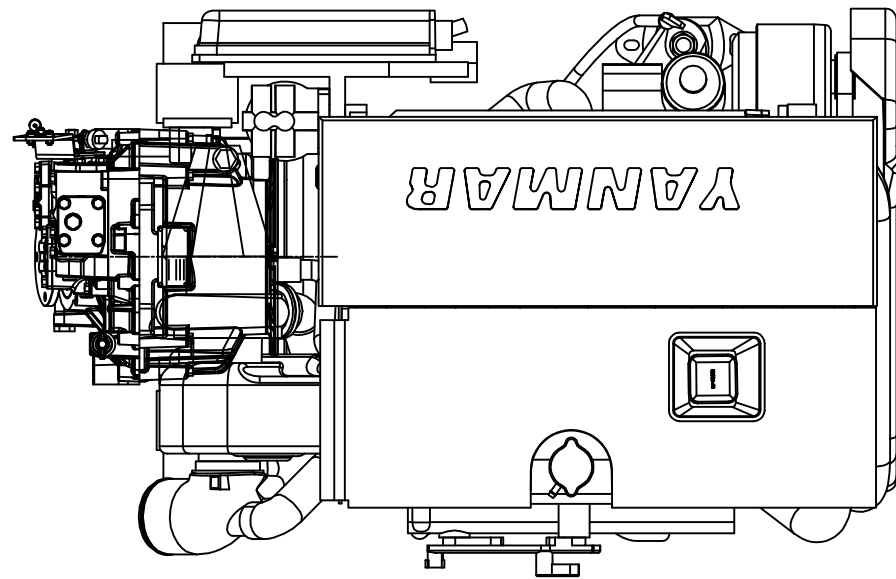
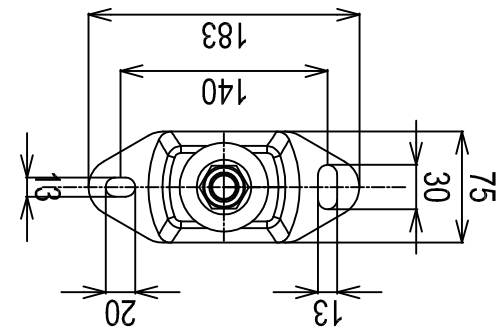
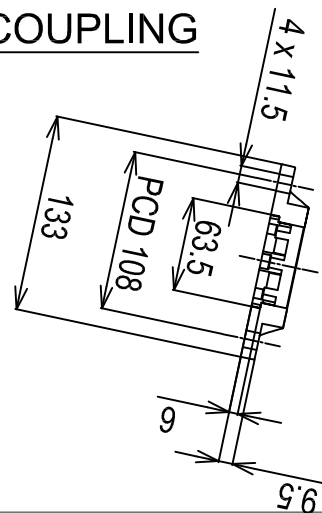

**PRELIMINARY COPY
ONLY**
NOT TO BE USED FOR PRODUCTION

NOTE:

- 1.DWG.SHOWS MOUNTING BLOCKS AT ORIGINAL HEIGHT. ENGINE WEIGHT WILL COMPRESS BLOCKS BY 4MM(APPROX).
- 2.MOUNTING BLOCKS ARE EQUIPPED FOR STANDARD ACCESSORY.
- 3.● SHOWS THE CENTER OF GRAVITY.
- 4.FOR ADDITIONAL INSTALLATION INFORMATION AND SPECIFICATIONS PLEASE REFER TO THE YANMAR ENGINE INSTALLATION MANUAL

Series: BY	Engine: 6BY2-260(220)xKMH50V	Release: R2009-01A
Scale: 1:10	Date: 27-08-09	Dimensions: mm

