

Yanmar type 6LPA-STZP2



Configuration	4-stroke, vertical, water cooled diesel engine
Maximum output at crankshaft	* 232 kW (315 mhp) / 3800 rpm ** 225 kW (306 mhp) / 3800 rpm
Continuous rating output at crankshaft	211 kW (286.4 mhp) / 3682 rpm
Displacement	4.164 L (254 cu in)
Bore x stroke	94 mm x 100 mm (3.70 in x 3.94 in)
Cylinders	6 in line cylinders, 4- valves per cylinder
Combustion system	Direct injection
Aspiration	Turbocharged with intercooler
Starting system	Electrical starting 12 V - 2.5 kW
Alternator	12 V - 80 A
Cooling system	Fresh water cooling by centrifugal fresh water pump and rubber impeller seawater pump
Lubrication system	Enclosed, forced lubricating system
Direction of rotation (crankshaft)	Counter clockwise viewed from flywheel side
Dry weight without sterndrive	428 kg (944 lbs)
Environmental	EU RCD, US EPA Tier 2, BSO II & EMC
Engine mounting	Rubber type flexible mounting

NOTE: Fuel condition: Density at 15°C = 0.84 g/cm³; 1kW = 1.3596 mhp = 1.3410 HP

* Fuel temperature 25°C at the inlet of the fuel injection pump (ISO 3046-1)

** Fuel temperature 40°C at the inlet of the fuel injection pump (ISO 8665 : 2006)

Dimensions (For detailed line-drawings, please refer to our web-site: www.yanmarmarine.com)

Front view

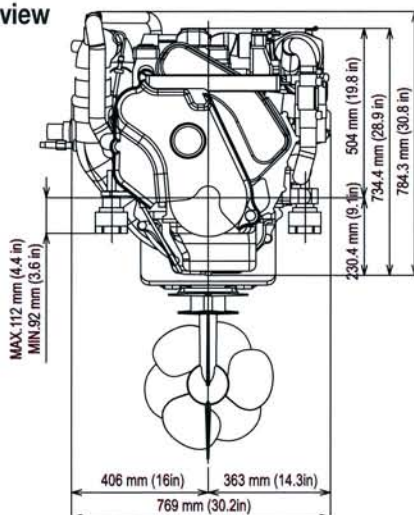

Right side view

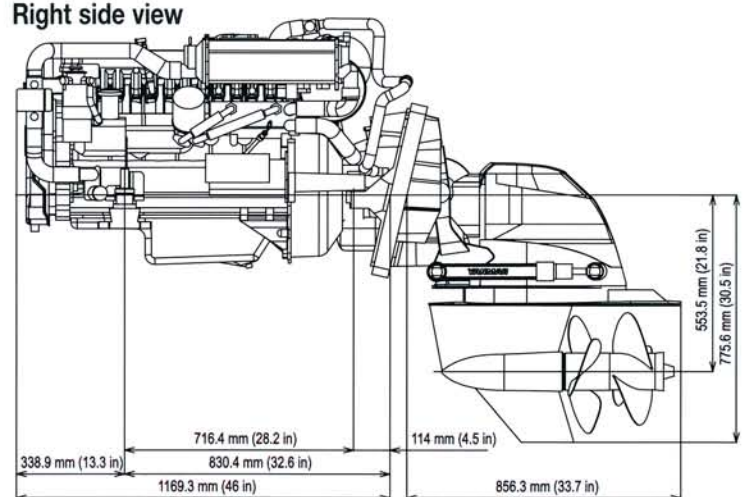

6LPA-STZP2 with ZT350 Sterndrive



Performance Curves (Output is according ISO 8665)

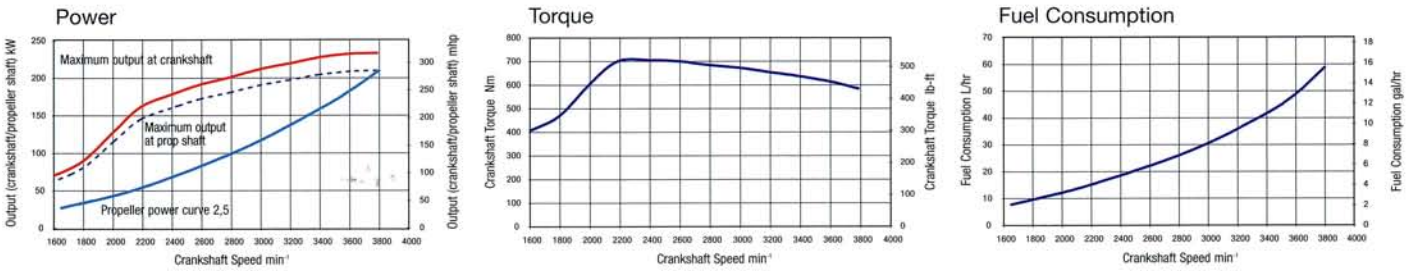

Yanmar Sterndrive engine set

Model	Sterndrive ZT350		Mercurier Bravo Sterndrive series							
	6LPA-STZP2		6LPA-STZP2							
Engine model	ZT350		Bravo 1X			Bravo 2X				
Type	ZT350		Bravo 1X			Bravo 2X				
Dry weight	99 kg (218 lbs)		88 kg (194 lbs)			94 kg (207 lbs)				
Reduction ratio (fwd/asn)	1.65/1.65	1.78/1.78	1.36/1.36	1.50/1.50	1.65/1.65	1.50/1.50	1.65/1.65	1.81/1.8	2.00/2.00	2.20/2.20
Propeller speed (fwd/asn)	2303/2303	2135/2135	2794/2794	2533/2533	2303/2303	2533/2533	2303/2303	2099/2099	1900/1900	1727/1727
Direction of rotation (propeller shaft - fwd)	Clockwise & counter clockwise viewed from flywheel side		Clockwise & counter clockwise viewed from flywheel side			Clockwise & counter clockwise viewed from flywheel side				
Dry weight engine with sterndrive	540 kg (1190 lbs)		604 kg (1332 lbs)			616 kg (1358 lbs)				

1. Inner and outer transome surface must be parallel within 3mm in area covered by transome plates and remain within transome thickness limits.
2. Dwg. shows mounting blocks at compressed height of approximately 4mm.
3. Transome angle: 13° to 16°

Instrument Panels

New B-type Panel

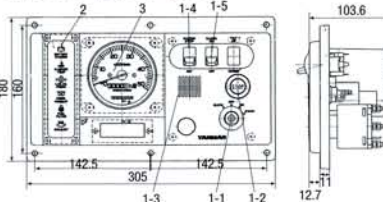

New C-type Panel

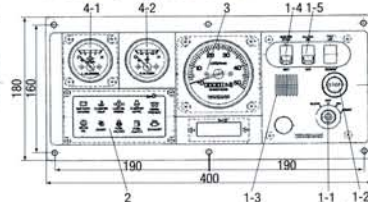

New D-type Panel

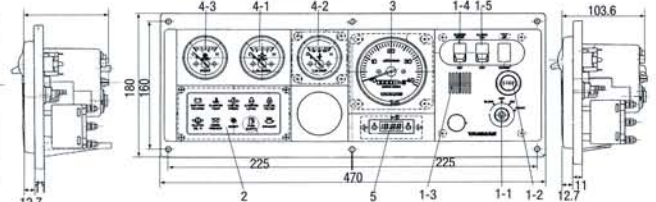

Function	Type of instrument panel		
	New B-type Panel	New C-type Panel	New D-type Panel
① Switch unit			
1-1 Key switch for GLOW/OFF/ON/START (4-position switch)	O	O	O
1-2 Engine stop switch	O	O	O
1-3 Alarm buzzer (C.W. Temp., L.O. Pressure)	O	O	O
1-4 Alarm buzzer stop switch	O	O	O
1-5 Illumination switch for meters	O	O	O
② Alarm lamp unit			
Battery not charging	O	O	O
C.W. high temperature	O	O	O
L.O. low pressure	O	O	O
F.O. drain separator (water level)	O	O	O
Sea water flow	O	O	O
C.W. level for fresh water tank	X	O	O
Boost pressure high	X	O	O
③ Tachometer with hour meter	O	O	O
④ Sub meter unit	X		
4-1 L.O. pressure meter	X	O	O
4-2 C.W. Temperature meter	X	O	O
4-3 Boost meter (turbo)	X	X	O
⑤ Quartz clock	X	X	O

Note: O = Equipped on panel X = Not equipped on panel

Accessories

Standard Package

- Sensor for instrument panel (New B, C and D-type)
- Exhaust mixing elbow (L-type thru' drive)
- Cooling water hoses

- Fuel water separator (integrated with fuel filter)
- Hydraulic Steering pump
- Alternator 12 V - 80 A

Optional

- Analog instrument panels (New B,C and D-type)
- Flexible mounts (2pcs)
- Exhaust mixing elbow, U-type (high riser transom type)
- Lub oil evacuation pump
- Remark: Engine also available without Hydraulic steering pump for twin installation

- Dipstick for opposite side
- Various Wire Harnesses (4,6,10 m)
- Tie Bar (for twin installation)
- VDO instrumentation for main panel and fly bridge

Texts and illustrations are not binding. Yanmar Marine reserves the right to introduce adaptations without prior notification.

6LPA-STZP2 Version: 2009-07